

Series 9311 Pneumatic & Electric Liquid Level Switch

Application

The WellMark Series 9311 is a Pneumatic Snap Acting or Electric Hi/Lo Level Switch. This switch combines the user-friendly features of our Model 2001NB with the rugged external cage of the Model 9321. Together these attributes make the 9311 a robust, reliable Level Switch for the control of liquid level in oil and gas production equipment such as Gas Compressor Scrubbers, Separators, Safety Systems, etc.

Features

- Pneumatic or Electric
- Weather Proof Case
- Left or Right Hand Mount
- Direct or Reverse Acting
- 304 and 316 Stainless Steel Internals
- NACE Process, Standard
- Electric Option Available (Consult Factory)

Specifications

Process Connection	Screwed 1" NPT
	Butt Weld 2.00", Socket Weld 1.00", Flanged (Consult Factory)
Temperature Rating	-20°F-400°F
Max. Working Pressure	2500 psi
Pilot Action	Pneumatic-Snap (On/Off)
Minimum Air Supply	20 psi
Minimum Specific Gravity	Pneumatic-0.5
Supply & Output Connection Size	Pneumatic-1/4" NPT
	Electric-1/2" NPT



Materials

Level Control	
Box	Die Cast Aluminum
Pilot	Aluminum w/S.S. Internals
Gauges	Brass (S.S. Optional)
Cage/Body Assembly	
Cage	Cast Steel
Body	1018 Steel
Displacer	S.S.
Displacer Arm	304 S.S.
Seals	Viton®

Dimensional Data

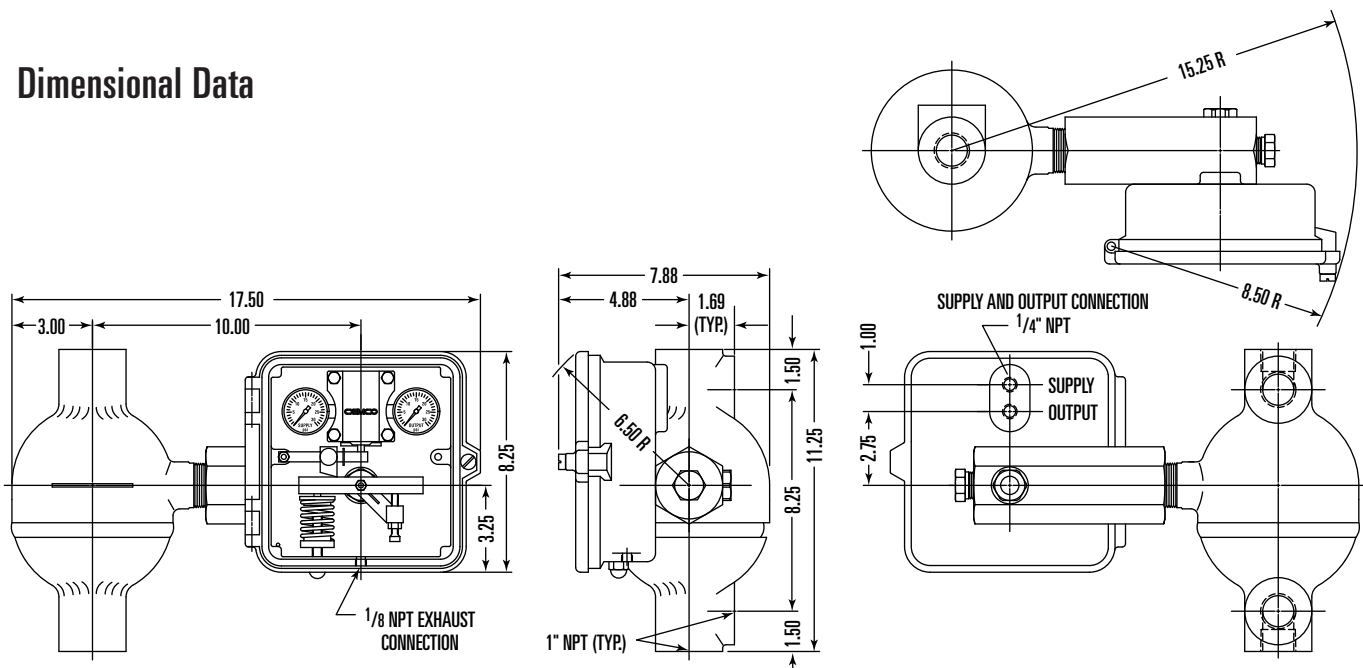

Series 9311 Pneumatic & Electric Liquid Level Switch

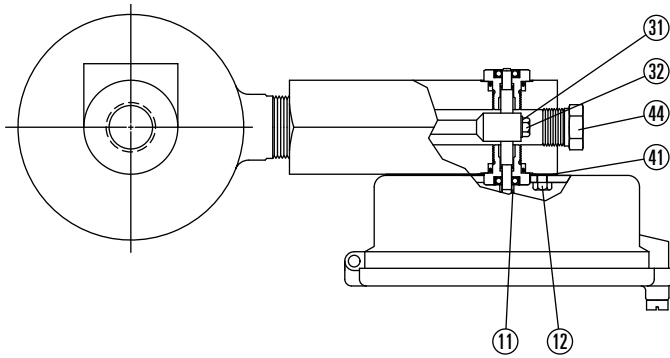

Determining the Model Number

Example given: Standard Model 9311-SLD, Snap Acting, Left Hand Mounting, Direct Control Level Switch.

MODEL 9311-SLD

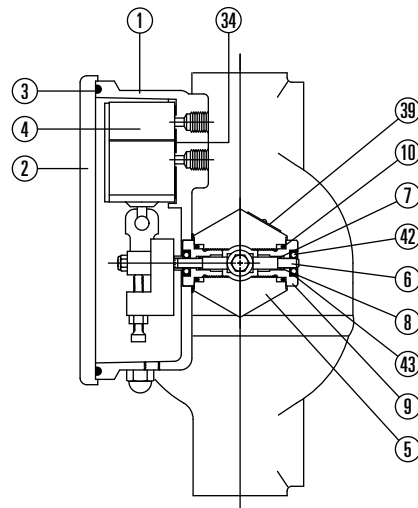
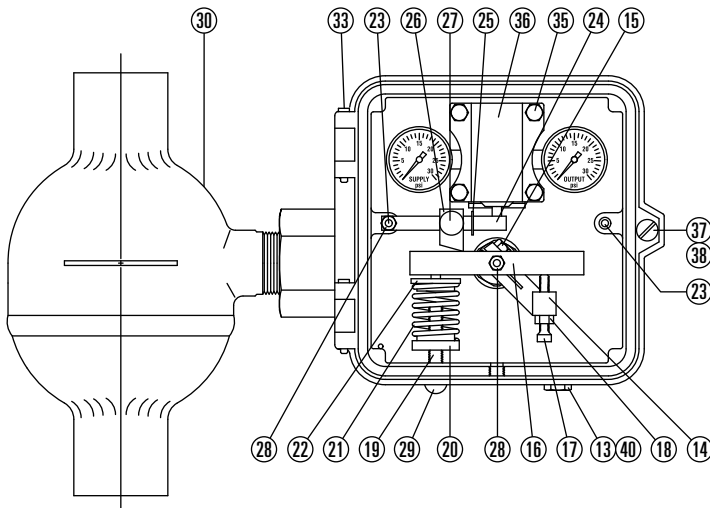
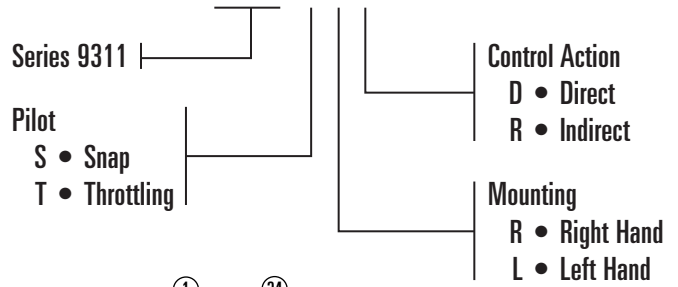

Parts List

Item	Description	Qty.	Part No.
1	CONTROL BOX, DIE CAST ALUMINUM	1	05012-4841
2	COVER, DIE CAST ALUMINUM	1	05012-4834
*3	BOX SEAL, NEOPRENE	1	06000-5097
*4	SNAP PILOT ASSEMBLY	1	06500-5304
	THROTTLE PILOT ASSEMBLY	1	06500-5387
5	BODY, ASTM A-108GR. 1018	1	05013-1458
6	PIVOT SHAFT, ASTM A-276 TY.316	1	05013-1482
*7	O-RING, VITON®	2	05000-0769
*8	BACK UP RING, TEFLON®	2	06000-1179
9	SHAFT RETAINER, ASTM A-276 TY.316	2	05012-9398
*10	O-RING, VITON®	2	05000-1155
11	SPACER, ASTM A-276 TY. 316	1	05011-4495
12	CAP SCREW, 18-8 S.S.	2	05000-5578
13	CAP SCREW, 18-8 S.S.	1	05000-5453
14	ADJUSTING BAR, ALUMINUM	1	05011-4438
15	CAP SCREW, 18-8 S.S.	2	05000-2526
16	TORQUE BAR, ALUMINUM	1	05011-4545
17	ADJUSTING SCREW, ASTM A-276 TY.316	1	05011-4537
18	JAM NUT, 18-8 S.S.	1	05000-2559
19	STUD, 18-8 S.S.	1	05011-4552
20	LOWER SPRING GUIDE, ALUMINUM	1	05011-4529
21	SPRING, ASTM A-313	1	06000-4157
22	UPPER SPRING GUIDE, ALUMINUM	1	05011-4479
23	STUD, FLAPPER BAR, ASTM A-276 TY.316	2	05012-9371
24	FLAPPER BAR	1	05011-4404

Item	Description	Qty.	Part No.
25	TRU-ARC RING, PH 15-7 MO	1	06000-1385
26	FULCRUM, ALUMINUM	1	05011-4412
27	THUMB SCREW, S.S./PLASTIC	1	06500-5429
28	NY-LOC NUT, STAINLESS STEEL	2	05000-2567
29	ACORN NUT, STAINLESS STEEL	1	05000-2575
30	CHAMBER W/FLOAT ARM	1	40299
31	LOCK WASHER	1	10709
32	CAP SCREW	1	10002
33	HINGE PIN, STEEL PLATED	2	06000-7537
34	GASKET	1	06000-4819
35	CAP SCREW	4	05000-5313
36	PILOT CLAMP	1	05012-6325
37	PANEL SCREW, STAINLESS STEEL	1	06000-1153
38	PANEL SCREW RETAINER, STAINLESS STEEL	1	06000-2672
39	SERIAL TAG, ALUMINUM	1	06000-1922
*40	THREAD SEAL, STEEL/BUNA N	1	06000-0395
*41	GASKET	1	10016
42	BEARING, STAINLESS STEEL	2	06000-7552
43	TOLERANCE RING, STAINLESS STEEL	2	06000-7560
44	PLUG	1	06000-1146
45	COVER GLASS, LEXAN (NOT SHOWN)	2	10916
46	COVER GLASS PLATE, S.S. (NOT SHOWN)	2	10915
47	COVER GLASS GASKET, NEOPRENE (NOT SHOWN)	2	10917
48	COVER SCREW, PLATED STEEL (NOT SHOWN)	8	001501-P

*Recommended Spare Part