

Controls and Valves for Industry

Monitoring And Controlling Liquid Levels Has Never Been Easier, or Safer.

Installed and field calibrated in just minutes, as no intrusion into the tank is required. Add the optional Hi-Low switches for pump functions or alarm points, or even a 4 to 20 milliamp signal to give you complete control over your fluid levels.

The Series 685 features an explosion-proof housing for added safety.

Vessel connections are available in an array of styles and materials.



Weather Proof Housing

Electro-Mechanical Liquid Level Monitor

The Series 685 Level Indicator operates by head pressure against the diaphragm which is transmitted by mechanical linkages to monitor and display local liquid levels onsite and remotely with the optional transmitter package.



Specifically designed for use in atmospheric (vented) tanks, standpipes, reservoirs, and similar vessels that in the past required strapping which exposed personnel to noxious fumes for monitoring liquid levels.

Featuring a $\pm 2\%$ level accuracy for tanks up to 60 feet tall, the Series 685 provides increased production and energy efficiency. The Hi-Low models are utilized to actuate valves or signal alarms. WellMark's Multi-Switch model can contain up to seven switches for various level related system functions.

Easy To Read Indicator

Large dial face is easily read from your vehicle window. An optional remote monitor can be installed for even easier access to data.

Dimensional Data

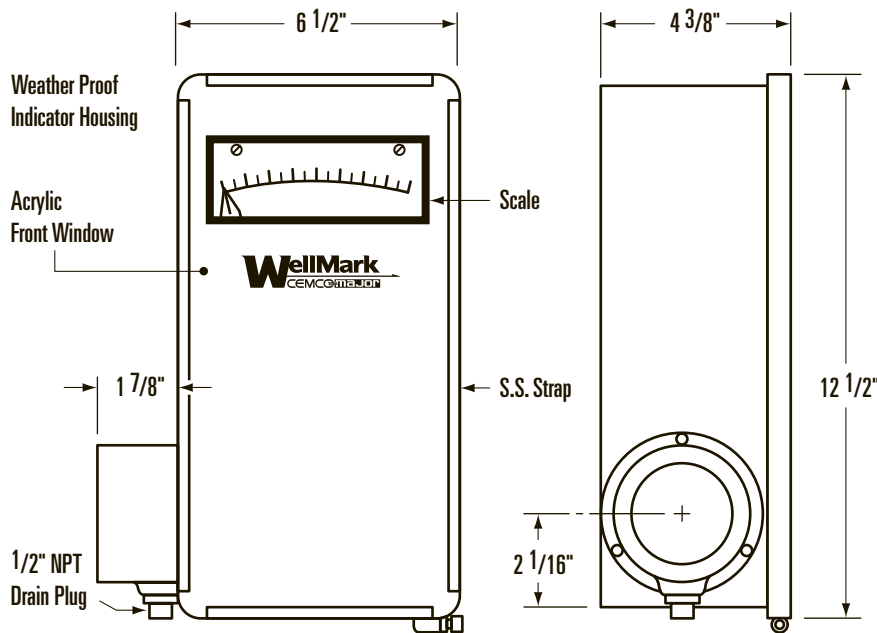

Specifications

Temperature Limit	300° F
Accuracy	+ -2%
Housing	Class I, Groups C & D; Class II, Groups E, F and G;
Rating	CSA Approved, LR-41663

Typical Installation

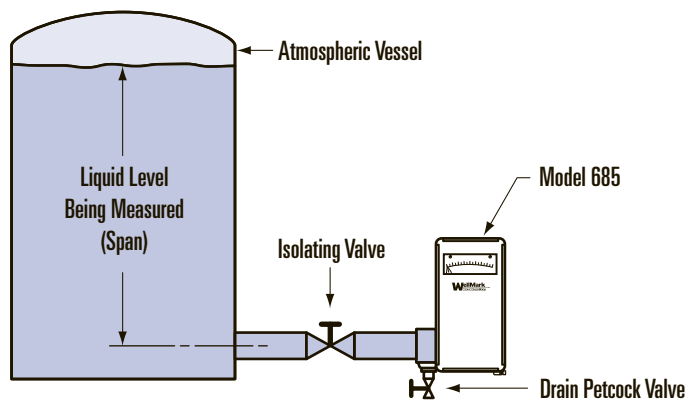

Contact your WellMark representative today for more information.

Which Model Is Right For You?

Model 685I • Indication of local liquid level only.

Model 685S • Indication of local liquid level plus Hi-Low switch output for pump start/stop, solenoid action or single alarm. • Multi-Switch style offers indication of local liquid level with one to seven switches for several switching output options.

Model 685E Transmitter • Indication of local liquid level with Proportional Output Transmitter for remote liquid level indication via Computers, Programmable Controllers and Radio Communication Devices.

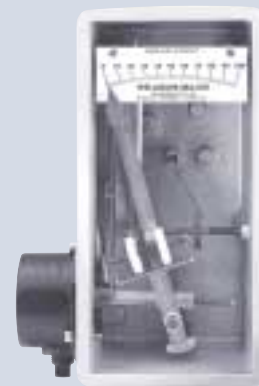

All component parts are manufactured from high quality materials and each unit is assembled to your exact specifications. The Wellmark Series 685 is easy to access, calibrate and maintain, making it the superior choice for liquid level management.