

685E Electric Liquid Level Indicator for Atmospheric Vessels

Application

The Model 685E Liquid Level Transmitter is an electro-mechanical level control device, which accomplishes three (3) main functions. These are remote indication, local liquid level indication, and hi-low adjustable switch outputs. The unit continuously indicates the liquid level and transmits a proportional signal.

Features

- Complementary Adjustments: Zero and Span adjustments at transmitter.
- Easy to Read: Scale reads the same as a hand tank gauge, making it unnecessary to convert psig of head pressure into feet and inches of liquid to get the correct reading.
- Special Scales: Gallons, Pounds, Percent, etc. is available.
- Long Life: All bearings are Teflon®, Delrin® or Moly Disulphide baked on Dry Film Lubricated Stainless Steel.
- Weather Proof and Explosion Proof Housing.

Operation

Liquid head pressure against a flexible elastomer diaphragm is transmitted directly to a leaf spring, which has a fixed pivot point at the upper end and an adjustable fulcrum point in the mid region of the leaf spring. For example, because 8' of heavy liquid exerts more pressure on the diaphragm than 8' of lighter liquid, the spring can be "stiffened" by moving the fulcrum down by the gravity adjustment knob (red), so the transmitter will still read 8'. The zero knob (green) moves the entire spring assembly and pointer, having the same effect as shifting the scale. The movement of the pointer rotates a shaft extending into the explosion proof housing where the electronic transmitter and switches are located. The shaft drives a potentiometer, thereby giving a continuous signal to the plug-in amplifier. The proportional signal is then transmitted to the remote indicating device in proportion to the liquid level which exists in the tank.

Installation

Since the unit measures liquid head pressure, the point at which it is installed on the vessel is the point that liquid measurement begins. For calibration and maintenance purposes, always install an isolation valve between the model 685E and the vessel. Also, install a drain petcock in the liquid inlet bottom, where a plug is generally located.

Specifications

Explosion Proof: CSA Approved Class I, Group C & D,
 Class II, Groups E, F and G hazardous locations.
 Temperature -20°F to +225°F Standard
 Pressure 0 to 4 ounces pressure (Atmospheric)
 Range (Vessel Height) 3' thru 60' (see 685 code sheet)
 Transmitter Output Four (4) Wires or Two (2) Wire System.
 Supply Voltage (at transmitter) ... 120 VAC, 60 Cycle, 1 phase (4-Wire)
 24 VDC (2-Wire)



Electrical Switches SPDT Micro Switch
 11 Amp @ 130 or 250 VAC, 1/2 Amp @ 125 VDC
 1/4 Amp @ 250 VDC, 4 Amp @ 125 VAC Induction
 Electrical Connections 1/2" Female Pipe Thread,
 3/4" Female Pipe Thread is also available as an option.

Dimensional Data

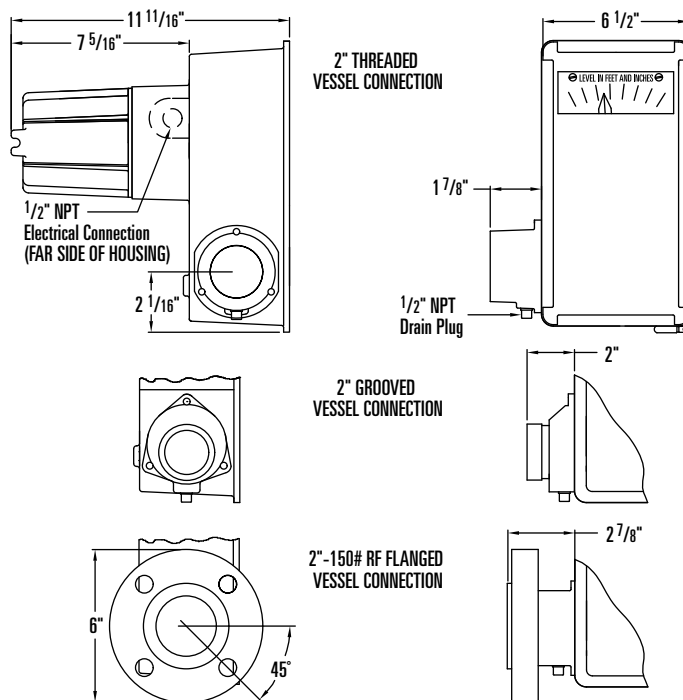

685E Electric Liquid Level Indicator for Atmospheric Vessels

Parts List

Item	Description	Qty.	Part No.
1	HOUSING, ALUMINUM	1	000153-M
2	POINT ASSEMBLY	1	000059-A
3	MAIN SPRING ASSEMBLY, STD.	1	000053-A
	MAIN SPRING ASSEMBLY, THIN	1	000054-A
	MAIN SPRING ASSEMBLY, DOUBLE	1	000055-A
4	ZERO KNOB, SHAFT & PIN	1	000010-A
5	ADAPTER	1	SEE CHART
6	PIPE PLUG, STEEL PLATED	1	002300-C
	PIPE PLUG, 304 S.S.	1	002304-P
	PIPE PLUG, 316 S.S.	1	002307-P
	PIPE PLUG, PVC	1	002301-P
7	SCREW, STEEL PLATED	3	001508-P
	SCREW, 2" NPT PVC ADAPTER ONLY	3	001542-P
	SCREW, 2"-150RF PVC ONLY	3	001553-P
8	ZERO SPRING, STAINLESS STEEL	1	003102-P
9	WEAR SPRING, STAINLESS STEEL	1	003103-P
10**	DIAPHRAGM, BUNA-N	1	000700-P
	DIAPHRAGM, VITON®	1	000713-P
	DIAPHRAGM, COMPOUND W	1	000720-P
	DIAPHRAGM, TEFLON®	1	000703-P
11	SCREW, 18-8 STAINLESS STEEL	1	001507-P
12	FOLLOWER BEARING, STAINLESS STEEL	1	003909-L
13	POINT DECAL	1	005900-P
14	SPRING BEARING, STAINLESS STEEL	1	000009-A
15	WASHER, TEFLON®	1	001807-P
16	RETAINER O-RING, NEOPRENE	1	003602-P
17***	SCALE, ALUMINUM	1	0030xx-P
18	SCREW, 18-8 STAINLESS STEEL	5	001504-P
19*	TAG, ALUMINUM	1	005908-B

*Not shown.

**Recommended spare parts. Other materials available.

***Specify tank height when ordering.

Item	Description	Qty.	Part No.
20*	BEZEL FRAME, STAINLESS STEEL	1	000023-P
21*	BEZEL SEAL	1	003400-P
22*	WINDOW, ACRYLIC	1	000204-S
23*	WASHER, PVC ADAPTER ONLY	1	001809-P
24	BELT	1	004310-P
25	WASHER, TEFLON®	4	001803-P
26	BUSHING, STAINLESS STEEL	1	002701-M
27	DRIVE SHAFT, STAINLESS STEEL	1	002810-M
28	PULLEY, STD.	1	004306-A
	PULLEY FOR TEFLON® DIAPH.	1	009680-A
29	SET SCREW, STAINLESS STEEL	2	001520-P
30	BRACKET AND CAM, ALUMINUM	1	000064-A
31*	COVER, ALUMINUM	1	000200-M
32	SCREW, STAINLESS STEEL	1	001807-P
33	BASE PLATE, ALUMINUM	1	001601-M
34	SPACER, ALUMINUM	2	001701-M
35	GEAR, 1 1/2" DIA., PLASTIC	1	004301-P
36	POT TO PLUG ASSY, 4 WIRE	1	000032-A
	POT TO PLUG ASSY, 2 WIRE	1	000033-A
37	TRANSMITTER, 4 WIRE	1	006500-M
	TRANSMITTER, 2 WIRE	1	006502-M
38	MICRO SWITCH, 685EC AND EE ONLY	2	000615-P
39	INSULATOR, 685EC AND EE ONLY	2	001216-P
40	SPACER, 685EC AND EE ONLY	2	002715-P
41	SCREW, 685EC AND EE ONLY	2	001506-P
42	WASHER, 685EC AND EE ONLY	2	001805-P
43	CAM, 685EC AND EE ONLY	2	000016-A
44	WIRE, 685EC AND EE ONLY	6	000086-A

Item #5 Part Number

Vessel Connection	Cad. Plated	Epoxy Coated	Teflon® Coated
2" NPT, D.I.	000307-C	000307-E	000307-T
2" NPT, 316 S.S.	000317-M*	000317-E	000317-T
2"-150RF, STEEL	000335-C	000335-E	000336-T
2"-150RF, 304 S.S.	000338-M*	000338-E	N/A
2"-150RF, 316 S.S.	000341-M*	000341-E	000341-T
3"-150RF, STEEL	000345-C	000345-E	N/A
2" GROOVE, D.I.	000302-C	000303-E	000302-T
2" NPT, PVC	000343-M*	N/A	N/A
2"-150RF, PVC	000342-M*	N/A	N/A

*Plating not required.

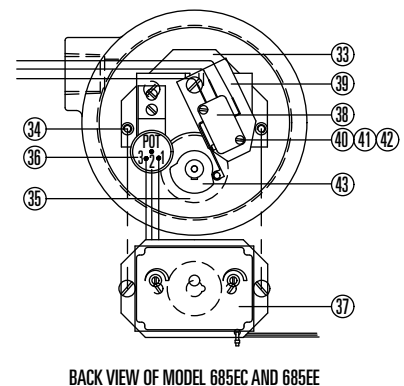
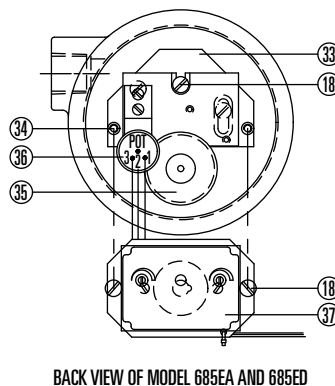
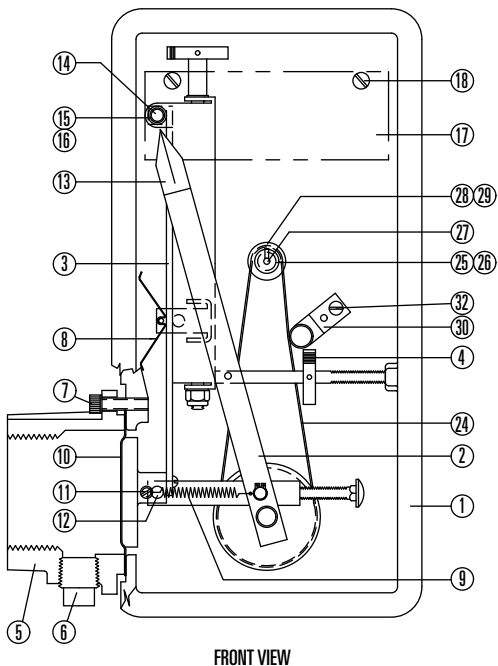

“Snubber” Pulsation Dampener for 685

Application

The Snubber is designed to permit the installation of the Major Level Control on a pump suction line without being affected by the surges as the pump starts or stops, or when any other condition results in rapid fluctuation of static head. Of the head type switches in common field use, only the Major Level Control is available with this built-in dampening feature.

Features

- **Dependable:** Factory-sealed snubber assembly eliminates the possibility of orifice plugging from foreign matter.
- **Effective:** Rapid pulsation pressure peaks up to 30 psig resulting in no visible pointer motion.
- **Cost Saving:** The Snubber eliminates the necessity of a separate tank connection and field wiring from the pump unit to the Level Control. The Level Control can be shop mounted and wired on a pump unit skid at a considerable saving in field installation cost.

Operation

Pressure on the upstream diaphragm forces the silicone oil through the orifice and against the downstream diaphragm. The orifice slows the rate of movement of silicone oil. If the head on the upstream diaphragm is suddenly increased from zero to 16', it takes 45 seconds for the pointer to reach the 16' reading. There is no disadvantage to this slowdown, since in normal operation it takes hours for the tank to fill from zero to 16'. The Snubber will operate satisfactorily at all ambient temperatures due to the almost flat viscosity-temperature curve of the silicone oil.

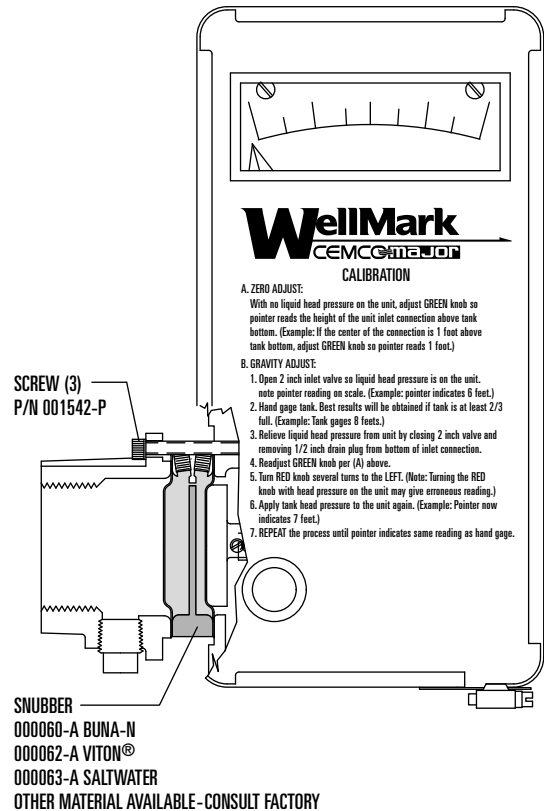

Installation (Snubber to 685)

1. Remove the three cap screws attaching the housing adapter to the level control housing.
2. Remove the diaphragm.
3. Insert the Snubber between the adapter and the housing with the convex (protruding) diaphragm exposed to the liquid.
4. Install the three long screws furnished with the Snubber. **NOTE:** Due to the slow action of the pointer when a Snubber is used, the Level Control can be calibrated more quickly if the Snubber is first removed. Installation of the Snubber will not affect calibration of the Level Control.

685 Liquid Level Indicator for Atmospheric Vessels

Determining the Model Number

Example given: Standard Model 685I-1G8-RN Liquid Level Indicator for Atmospheric (Vented) Vessels with, Level Indication Output, 2" NPTF (Cad Plated Ductile) Tank Connection, Buna-N Diaphragm, 0 to 16 Foot Indicator Scale, Standard Aluminum Housing.

MODEL 685 I-1 G 8-R N,X

