

W9501, W9502, and W9503 Threaded Safety Relief Valves

Application

These valves are for general purpose gas and air services, and are recommended for over-pressure protection on separators, compressors, pressure vessels, heater-treaters, gathering and transmission lines, meter runs, and other systems where the rated capacities of the valve are commensurate with the requirements of the system. All of these valves are manufactured in accordance with the ASME Boiler and Pressure Vessel Code and have been capacity tested and certified by the National Board to meet the requirements of Section VIII of the ASME Code, as signified accordingly by the symbols "UV" and "NB" on their nameplates.

Features

- Curtain - Disc Design: High Capacity - Low Blow Down
- ASME Coded: "UV" Section VIII Air/Gas
- Guided Lift System: Optimum Performance
- Trim Option: Soft Seat, Metal to Metal (3" Soft Seat Only)
- High Volume Applications
- Low Pressure Applications
- Stainless Steel Internals
- NACE Option Available (Std. On 3" Valves)

Specifications

Type 9501—1" Size

W9501R (Metal to Metal Seat), W9501RS (Soft Resilient Seat)

90% Slope=2.41, .500 Orifice (.196 Sq. In.)

Type 9502—2" Size

W9502R (Metal-to-Metal Seat), W9502RS (Soft Resilient Seat)

90% Slope=7.57, .850 Orifice (.567 Sq. In.)

Type 9503—3" Size

W9503RS (Soft Resilient Seat)

90% Slope=36.12, 2.000 Orifice (3.142 Sq. In.)

Dimensional Data

Model	A	B	C	D	E	F
W9501	2 3/8	10 1/2	3 1/4	1 7/8	1" FNPT	1" MNPT STD. 3/4" MNPT OPT. 1/2" MNPT OPT.
W9502	2 7/8	12 3/8	4 1/2	2 3/8	2" FNPT	2" MNPT STD. 1 1/4" MNPT OPT. 1 1/2" MNPT OPT.
W9503	4" MAX.	17 1/2"	4 5/8"	4 5/8"	3" FNPT	3" FNPT

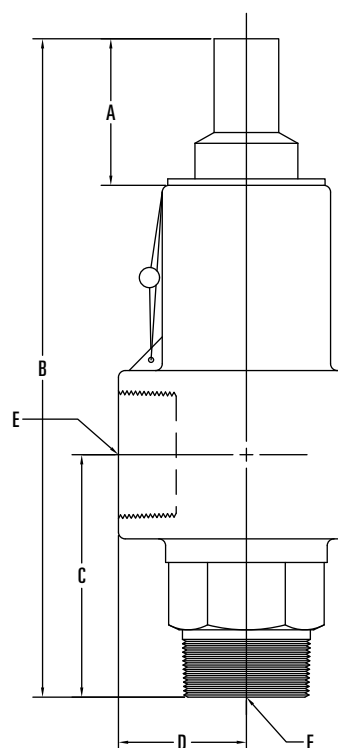

W9501, W9502, and W9503 Threaded Safety Relief Valves

Determining the Model Number

MODEL W9501-RS-A-400

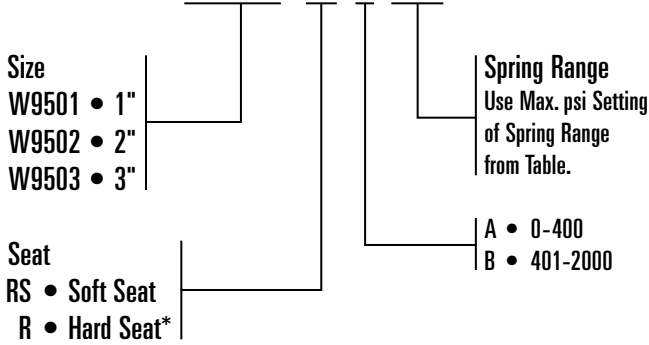

*Available in 1" & 2" Only.

Size	Model No.	SCFM*	Max PSI Setting	Pressure Range	Spring
W9501 1"	TYPE - 25	102	25	3 - 25	10307
	TYPE - 200	565	200	25 - 200	10308
	TYPE - 400	1095	400	200 - 400	10309
	TYPE - 600	1626	600	400 - 600	10310
	TYPE - 800	2156	800	600 - 800	10311
	TYPE - 1200	3216	1200	800 - 1200	10312
	TYPE - 1600	4277	1600	1200 - 1600	10314
	TYPE - 2000	5337	2000	1600 - 2000	10316
W9502 2"	TYPE - 30	361	30	3 - 30	10296
	TYPE - 150	1360	150	30 - 150	10297
	TYPE - 400	3442	400	150 - 400	10298
	TYPE - 600	5107	600	400 - 600	10299
	TYPE - 900	7605	900	600 - 900	10301
	TYPE - 1200	10103	1200	900 - 1200	10304
	TYPE - 1500	12601	1500	1200 - 1500	10797
	TYPE - 1800	15099	1800	1500 - 1800	10798
W9503 3"	TYPE - 25	1542	25	15-25	05011-7233
	TYPE - 60	2806	60	26-60	05011-7241
	TYPE - 125	5497	125	61-125	05011-7258

*SCFM = For set pressures up to 75 psi
Pressure setting plus 3 psi plus atmospheric pressure (14.7 psi) times 90% slope
*SCFM = For set pressures over 75psi
Pressure setting times 1.1 plus atmospheric pressure (14.7 psi) times 90% slope
Minimum ASME settings: 20 psi for 1", 30 psi for 2", and 15 for 3".

Sizing of Safety Relief Valves

Given certain information as follows, Safety Relief Valves may be sized by use of various formulas prescribed by Appendix 11, Section VIII, Division I of the ASME Boiler and Pressure Vessel Code for capacities of orifices.

Table I – Value Data

Valve Size	Valve Type	Bore	KA	90% KA	Slope*	90% Slope
1"	W9501RS	.500	.146	.131	2.68	2.41
1"	W9501R	.500	.146	.131	2.68	2.41
2"	W9502RS	.850	.458	.412	8.41	7.57
2"	W9502R	.850	.458	.412	8.41	7.57
3"	W9503RS	2.000	2.188	1.969	40.12	36.12

* ASME certified slopes determined by actual tests conducted at the National Board Testing Laboratory, Columbus, Ohio.
NOTE: When sizing for code application, use 90% KA or 90% Slope.

Table II – Molecular Weight and Values of C for Gases

Gas	M	C
AIR	28.97	356
ACETYLENE	26.04	345
AMMONIA	17.03	351
BUTANE	58.12	324
CARBON DIOXIDE	44.01	345
CHLORINE	70.91	352
ETHANE	30.07	339
ETHYLENE	28.05	337
FREON 22	86.48	355
HYDROGEN	2.02	356
HYDROGEN SULFIDE	34.08	348
METHANE	16.04	346
METHYL CHLORIDE	50.48	337
NATURAL GAS (0.6)	17.40	344
NITROGEN	28.02	356
OXYGEN	32.00	356
PROPANE	44.09	331
SULFUR DIOXIDE	64.06	342

Table III – Formulas

Q (SCFM) = Pressure Setting times 1.1 plus atmospheric pressure (14.7 psia) times 90% slope.

$$Q \text{ (SCFM)} = \frac{KACP}{w \times 60} \sqrt{\frac{M}{T}}$$

$$W \text{ (lb/hr)} = KACP \sqrt{\frac{M}{T}}$$

$$KA = \frac{Wa}{CP} \sqrt{\frac{T}{M}}$$

Where:

- Q = Required flow (scfm) thru valve at 14.7 psia and 60°F
- SCFM = Standard cubic feet per minute.
- KA = Product of effective coefficient of discharge and the effective discharge area.
- C = Coefficient determined by ratio of the specific heats of gas or vapor at standard conditions.
- P = Set pressure x 1.1 plus atmospheric pressure (14.7 psia)
- w = Density of gas (lb./cu. ft.) at 60°F, and 14.7 psia (air being .0764 lb. cu. ft.)
- M = Molecular weight
- T = Absolute temperature at inlet (°F + 460)
- W = Flow of any gas or vapor, lb./hr.
- Wa = Rated capacity, converted to lb./hr. of air at 60°F, inlet temperature.

W9501, W9502, and W9503 Threaded Safety Relief Valves

Parts List, W9501 and W9502

Item	Description	Qty.	Part No.	
			W9501-1"	W9502-2"
1	CAP, PLASTIC	1	10175	10196
2	ADJUSTMENT SCREW, PLATED STEEL	1	10173	20339
3	LOCK NUT, PLATED STEEL	1	10174	10141
4	SEAL WASHER, STEEL/BUNA-N	1	10578	10594
5	SPRING GUIDE, STEEL	1	20745	20751
	SPRING GUIDE FOR 2" 1500, 1800, STEEL	1	—	20798
6	1" SPRING, S.S. 3-25 PSI	4	10307	—
	1" SPRING, S.S. 25-200 PSI	1	10308	—
	1" SPRING, S.S. 200-400 PSI	1	10309	—
	1" SPRING, S.S. 400-600 PSI	1	10310	—
	1" SPRING, S.S. 600-800 PSI	1	10311	—
	1" SPRING, S.S. 800-1200 PSI	1	10312	—
	1" SPRING, S.S. 1200-1600 PSI	1	10314	—
	1" SPRING, S.S. 1600-2000 PSI	1	10316	—
6	2" SPRING, S.S. 3-30 PSI	1	—	10296
	2" SPRING, S.S. 30-150 PSI	1	—	10297
	2" SPRING, S.S. 150-400 PSI	1	—	10298
	2" SPRING, S.S. 400-600 PSI	1	—	10299
	2" SPRING, S.S. 600-900 PSI	1	—	10301
	2" SPRING, S.S. 900-1200 PSI	1	—	10304
	2" SPRING, S.S. 1200-1500 PSI	1	—	10797
	2" SPRING, S.S. 1500-1800 PSI	1	—	10798
7	BONNET, CAST STEEL	1	30153	30449
8	DISC GUIDE, S.S.	1	20746	20752
9	PLUG DISC, S.S.	1	20747R	20753
	PLUG DISC FOR 2" 1500-1800, S.S.	1	—	20799
10	SHELL, SOFT SEAT, S.S.	1	20748R	30754
11	O-RING, VITON®	1	10696	05000-0983
12	CYLINDER, SOFT SEAT, S.S./VITON®-70 DURO	1	20749R	20755A
13	O-RING, VITON®	1	10404	10381
14	O-RING, VITON®	1	10403	10380
15	SEAT FRAME, STEEL (1" NPT & 2" NPT)	1	20750	20756
16	O-RING, VITON®	1	10402	10379

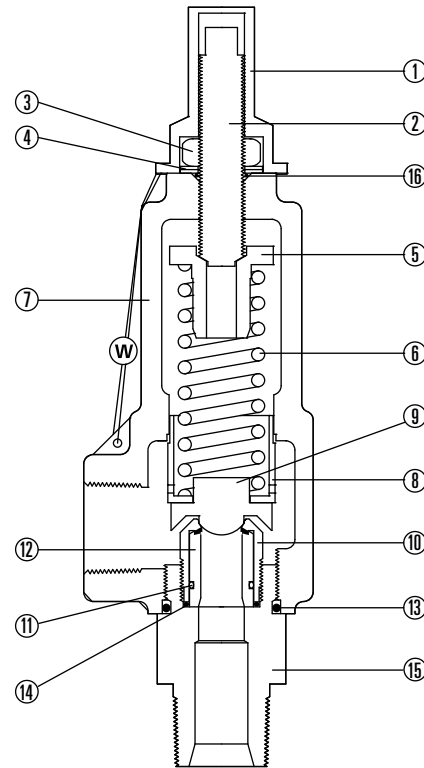

Parts List, W9503

Item	Description	Qty.	Part No.
1	VALVE BODY, DUCTILE IRON SA-395	1	05011-7191
2	SPRING HOUSING BONNET, DUCTILE IRON SA-395	1	05011-7274
3	SEAT, ASTM A-484 TY. 304	1	05012-7960
4	O-RING, VITON®	1	05000-1262
5	BLOW DOWN RING ASSY., ASTM A-484 TY. 304	1	06500-5132
6	O-RING, VITON®	1	05000-1288
7	HEX SCREW, SA-307 GR. A	4	05000-2013
8	SPRING GUIDE, ASTM A-108	1	05011-7266
9	ADJUSTMENT SCREW, SA-307 GR. B	1	05011-7282
10	JAM NUT, 304 S.S.	1	05000-2088
11*	SPRING 15-25 PSIG, 17-7 S.S.	1	05011-7233
	SPRING 26-60 PSIG, 17-7 S.S.	1	05011-7241
	SPRING 61-125 PSIG, 17-7 S.S.	1	05011-7258
12	NAME PLATE, ALUMINUM	1	10751
13	THREAD SEAL, STEEL/BUNA	1	10578

*Inconel® Optional

